

BASE VALVE

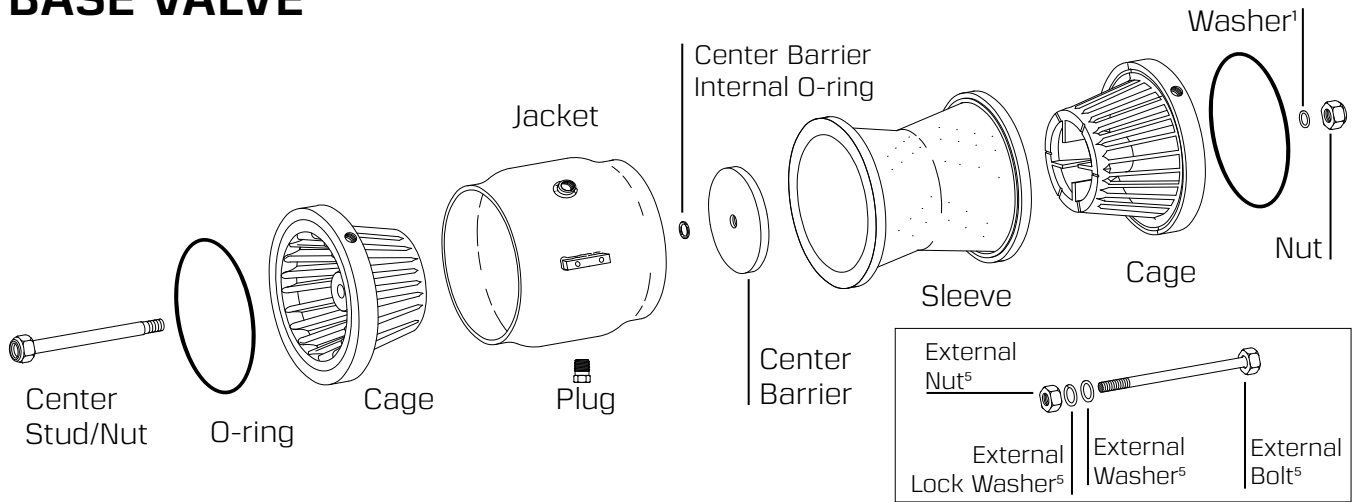

	2"	3"	4" Pre-2011 ³	4" 2011-Current	6"	8"
Center Stud/Nut Assembly	9754	9755	9756	11409	9757	9758
Nut (2)	9402	9402	9152	9152	9684	9684
Washer ¹	6110-001	6110-001	-	6115-001	13347	13347
Cage (2)						
Cast Iron - Threaded FNPT	9506-001	9382-001 ²	-	-	-	-
Cast Iron - Threaded FBSP	9506-002	9382-002 ²	-	-	-	-
Cast Iron - Victaulic	9505	9334	-	-	-	-
Cast Iron - Wafer	9504	9380	9150 ²	11445	9608	9391
Aluminum - Wafer	11141	11158	-	11208	12913	13141
O-Ring (2) (Wafer Only)	9522	9484	-	11416	9639	9485
Jacket	9500	9381	NA	11206	9646	9395
Plug	6089 (1/4")	6089 (1/4")	9174 (3/8")	9174 (3/8")	9185 (1/2")	9185 (1/2")
Center Barrier Internal O-ring	9483	9483	9148	9148	9721 ⁷	9721 ⁷
Center Barrier	9502-001	13167 ⁶	9147 ²	11209	13082 ⁶	13541 ⁶
Sleeve - 10-50 psi	9501-002	9383-002	9146-002 ²	11207-002	9697-002 ⁴	9393-002
Sleeve - 18-80 psi	9501-003	9383-003	9146-003 ²	11207-003	9697-003	9393-003
Sleeve - 30-200 psi	9501-001	9383-001	9146-001 ²	11207-001	9697-001 ⁴	9393-001
External Bolt (3) ⁴	9636	9584	-	-	-	-
External Washer (3) ⁴	9748	9748	-	-	-	-
External Lock Washer (3) ⁴	9749	9749	-	-	-	-
External Nut (3) ⁴	9585	9585	-	-	-	-
Mounting Bracket	See Page 6					
Manual Selector	See Page 3					
Stud Kit	See Page 5					

Notes:

- For aluminum wafer cage only; installed on downstream end of center stud.
- Contact factory for availability.
- See page 7 for description of 4" 2011 design change.
- Old style (pre-1996) sleeves (#8961-002, 10-50 psi / #8961-001, 30-200 psi). See page 8 for details.
- For threaded and victaulic valves only.
- New-style, two-piece, black center barrier assembly includes center barrier internal o-ring.
- O-ring #9721 is for new style two-piece center barriers. Previous 6" and 8" center barrier versions use o-ring #8973.

800P

2" PIVOT END GUN VALVE

All valves include C3 (18-80 psi) sleeve, aluminum cage, #10752 ball vent, and 2 rubber drains

Part Number	Description	Stud Kit	Connection
13271-003	800P A2B12C3 End Gun Valve, no stud kit	-	Wafer
13271-001	800P A2B11C3 End Gun Valve, with stud kit	#10142-001, 1/2" x 8.25", 4 studs, 4 nuts	Wafer
13271-005	800P A2B25C3 End Gun Valve, with 2" FNPT flanges	#10142-101, 1/2" x 8.25", 4 studs, 8 nuts	2" FNPT Flange (#10356)

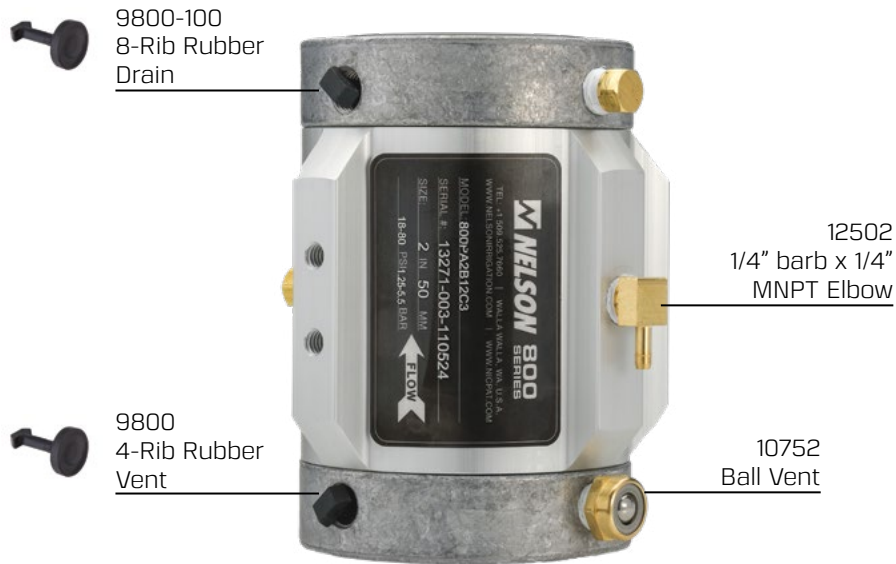

10753 Ball Vent Kit

Order separately to prevent booster pump air lock. (#10752 is included with valve as shown above)



13271-005 Threaded Valve

For Valmont machines, the 800P is typically installed at the booster pump outlet, remote from the end gun. Also useful when replacing an existing threaded end gun valve from others.

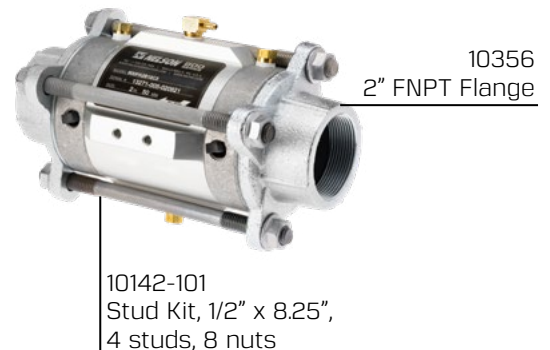

MANUAL SELECTOR

THREE-WAY (OPEN/CLOSE/AUTO), 1/8" FNPT PORTS

8980 - Manual Selector Kit

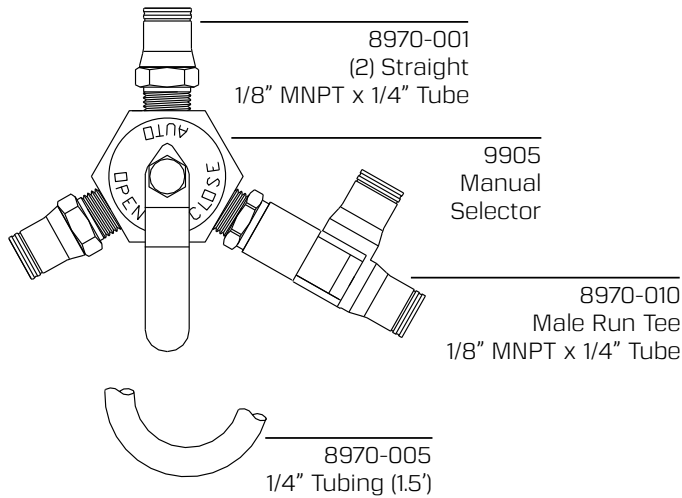

9905 - Manual Selector
(includes adapter and o-ring)

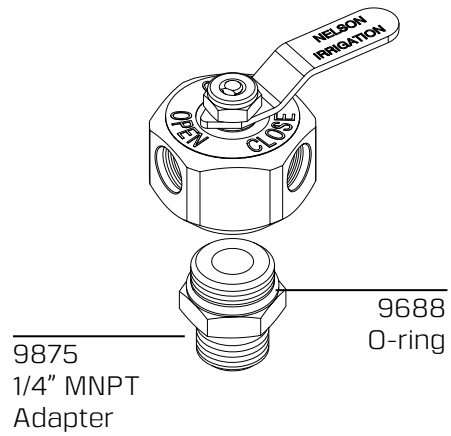

SLEEVE CODES

IDENTIFICATION OF MANUFACTURED DATE AND PRESSURE RATING

Detail of Sleeve Code

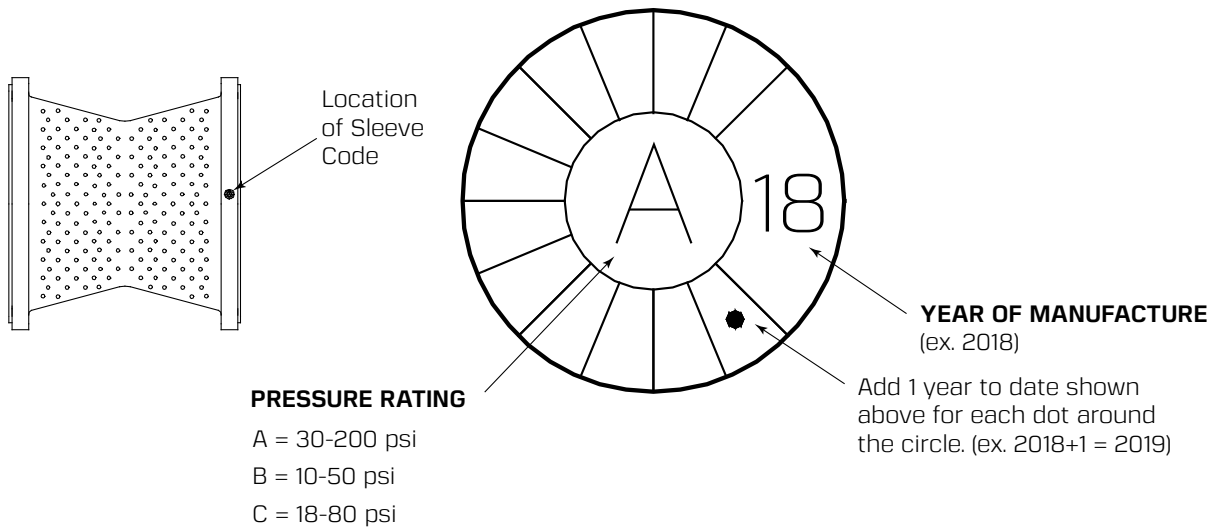

FILTERS

INTERNAL AND EXTERNAL

All filters use a 100 mesh screen. External filters have a larger surface area and are easier to clean, thus they are preferred in applications with dirty water.

INTERNAL FILTER PARTS

Description	2" & 3" Valves	4", 6", & 8" Valves
Internal Filter Assembly	9804-001	9804-002
Filter Adapter	9801	9801
Screen, 100 mesh	8413	9088
Screen Support	9803	9802

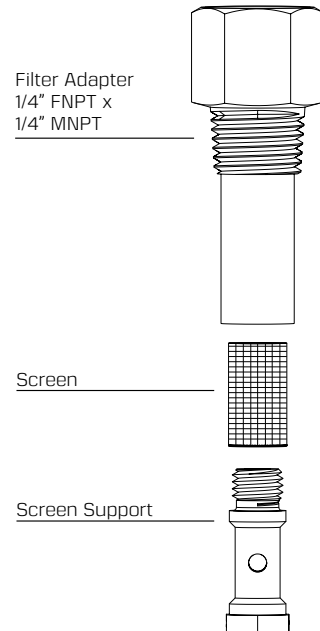

EXTERNAL FILTER PARTS

Description	Part Number
External Filter Kit with Bracket	9408
External Filter Kit without Bracket	9003
Mounting Bracket Kit (see page 6)	9189

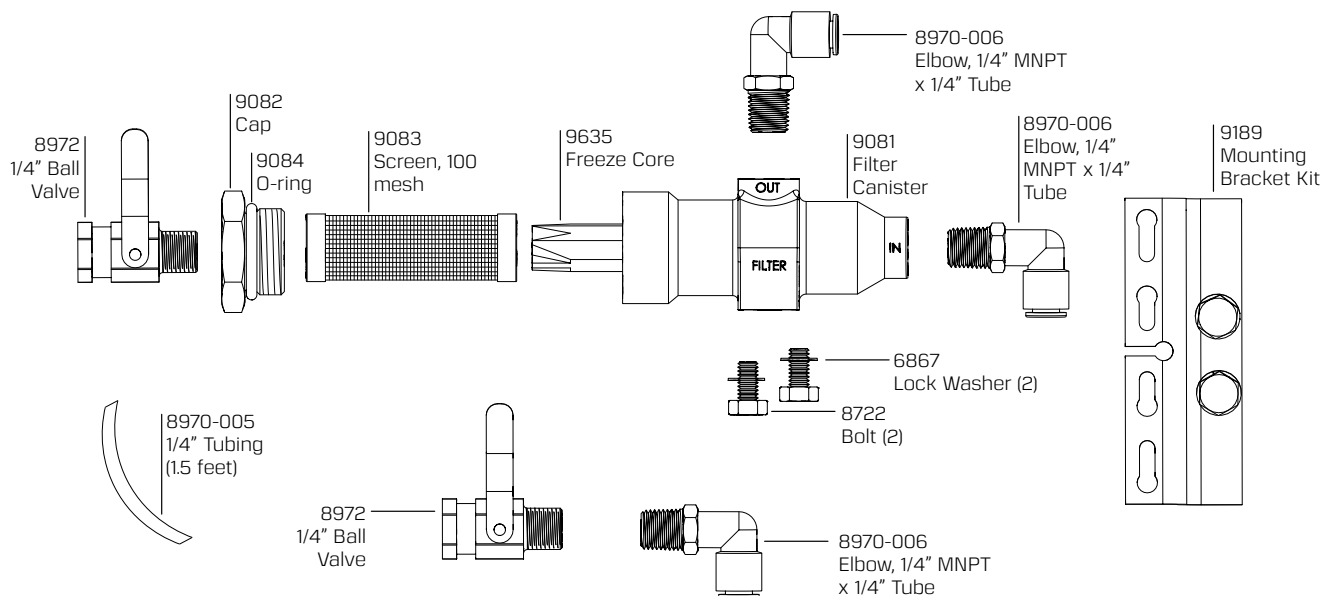

STUD KITS & FLANGE ADAPTERS

STUD KITS

Valve Size	Valve Model Numbers	Stud Kit Part #	Studs					Nuts		Washers	
			Dia.	Stud Length	Thread Lgth. (min.)	Qty.	Part #	Qty.	Part #	Qty.	Part #
2"	A2B5, A2B10	10142-102	1/2"	9.75"	2"	4	10140-002	8	10370	-	-
	A2B11, A2B17, A2B18	10142-001	1/2"	8.25"	2"	4	10140-001	4	10370	-	-
3"	A3B5, A3B10	9528	5/8"	11.5"	3"	4	9180	8	9181	8	9183
	A3B7*, A3B11*, A3B17, A3B18	10142-002	1/2"	9.75"	2"	4	10140-002	4	10370	-	-
4"	A4B5, A4B10	11413	5/8"	12"	2"	8	11386	16	9181	16	9183
	A4B7*, A4B11*, A4B17, A4B18	10142-003	1/2"	10.75"	2.5"	8	10140-003	8	10370	-	-
6"	A6B5, A6B10	8976	3/4"	13.5"	2"	8	8969	16	8974	-	-
8"	A8B5, A8B10	9524	3/4"	16.5"	2.25"	8	9521	16	8974	-	-

*Discontinued

FLANGE ADAPTER KITS

Description	Kit Part Number	Included Stud Kit	Flange Adapter Assembly	
			Assembly Part #	Adapter O-Ring
4" Valve x 6" Flange Adapter Kit	11433	-	11432	9639
4" Valve x 6" Flange Adapter Kit, with stud kit	11433-001	8976	11432	9639
6" Valve x 8" Flange Adapter Kit	12225	-	12159	12536 (small) 9485 (large)
6" Valve x 8" Flange Adapter Kit, with stud kit	12225-001	9524	12159	12536 (small) 9485 (large)

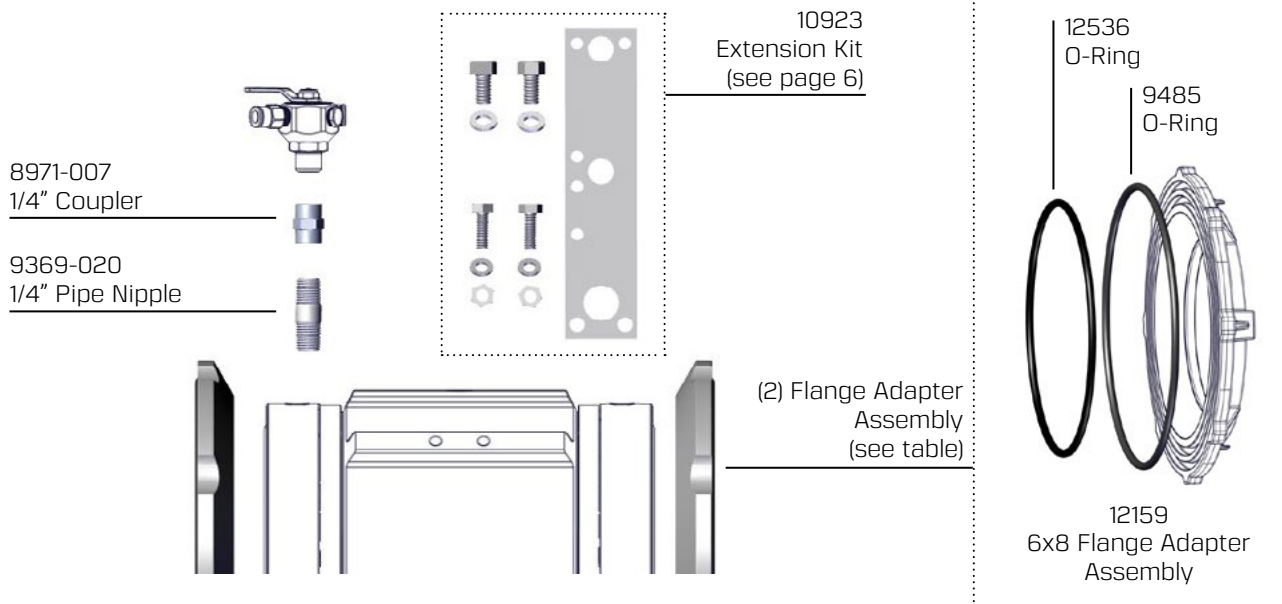

MOUNTING BRACKETS

Mounting brackets for attaching accessories such as a solenoid, pressure control pilot, and/or filter to 800 Series Valves.

Application	Kit Part Number	Bracket
For 2" Valves and External Filters	9189	9188
For 3" - 8" Valves	8924	8983
For E29 Solenoids, All Valve Sizes	12532	8983-100

All kits include (2) 6482 Bolts and (2) 7029 lock washers.

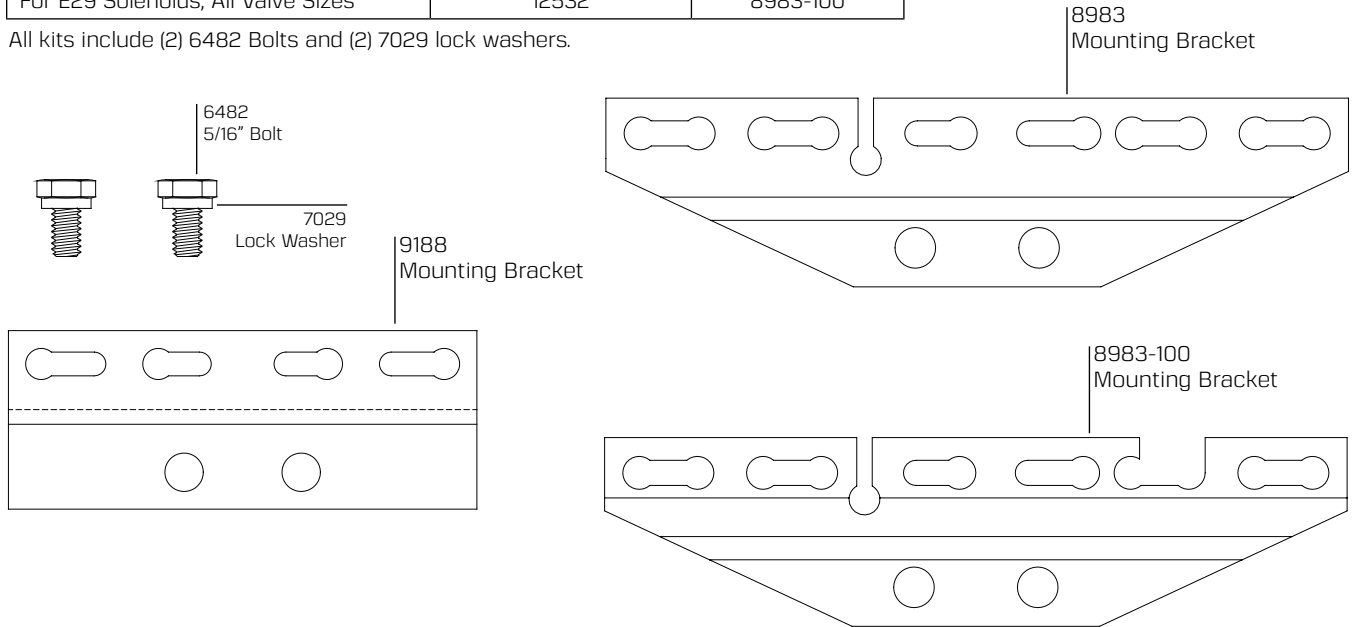

EXTENSION BRACKET KIT #10923

Use in conjunction with the standard mounting kits shown above to allow better access to accessories when the valve is installed low to the ground, or when flange adapter kits are used. Can also be used to mount the manual selector remote from the valve.

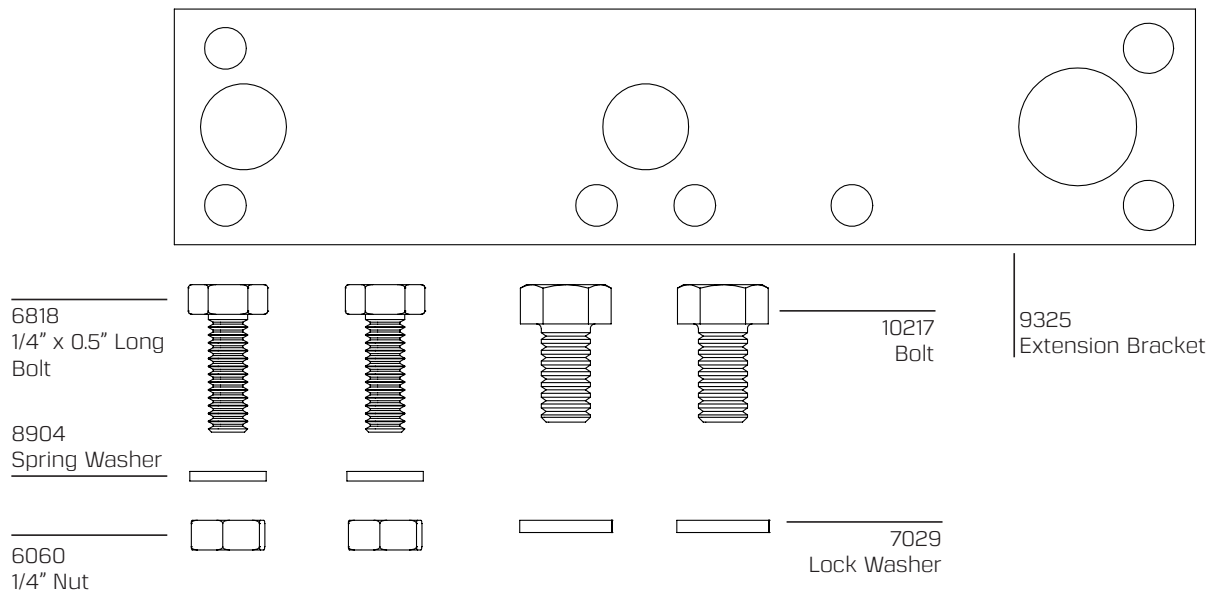

4" VALVE 2011 REDESIGN

The 4" Valve was redesigned in January 2011. "New" and "old" style parts are not interchangeable. Contact factory for availability of parts for pre-2011 valves.

2011-Current

Pre-2011

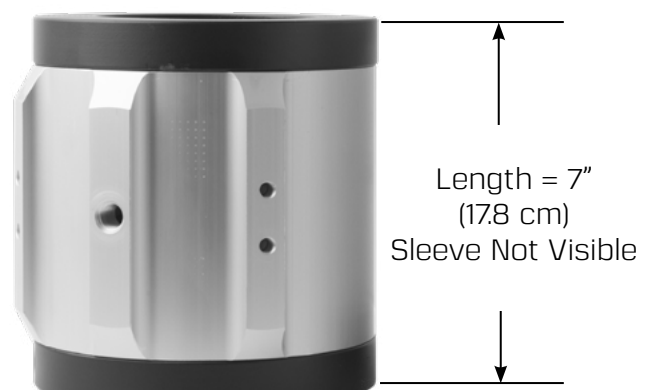
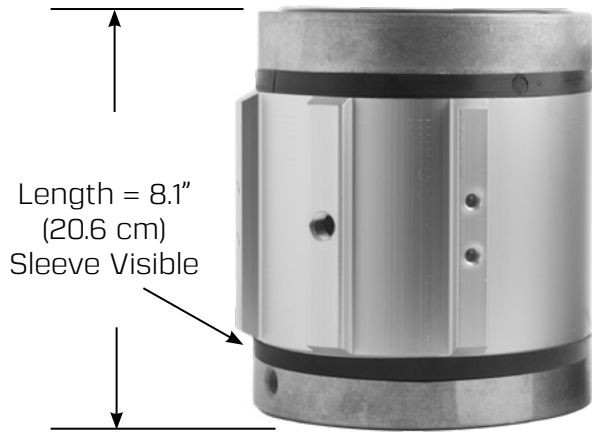

Sleeve

Sleeve



Cage

Cage



6" VALVE DESIGN CHANGES

The 6" Valve was redesigned in 1996. Pre-1996 ("old style") parts are not compatible with the "new" style valve. Minor periodic revisions to the sleeve and center barrier since 1996 are shown below and are compatible with all post-1996 valves.

SLEEVE

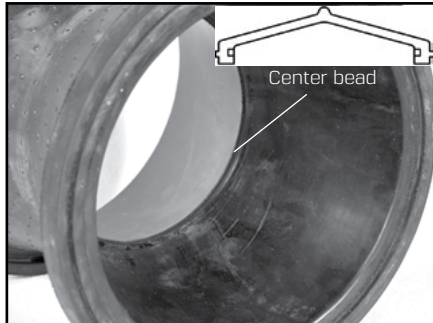

2001-Present
No ribs. Center bead.

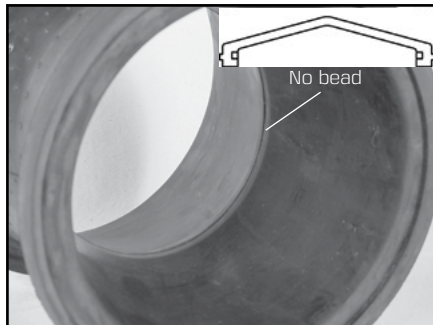

1996-2000
No ribs. No center bead.
Discontinued

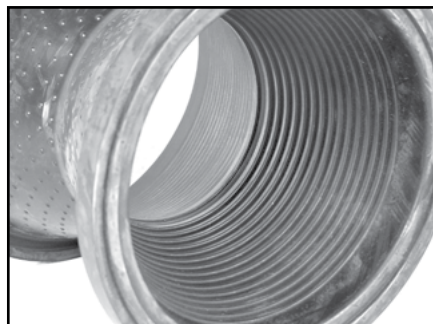

Pre-1996 Old Style
Ribs on inside of sleeve.
Contact factory for availability

CAGE

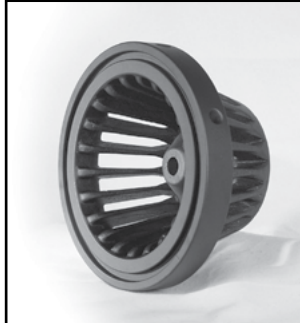

1996-Present
O-ring groove

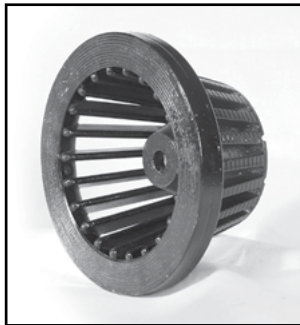

Pre-1996 Old Style
Ridged face
requires gasket
Discontinued

CENTER BARRIER



2022-Present
Black, Molded
Two-Piece, Plastic
Curved Edge
#13082

Previous versions use center o-ring #8973



2008-2021
White, Plastic
(UHMW)
Curved Edge
Discontinued



1999-2008
Brass
Curved Edge
Discontinued



Late 1996-1998
Brass
Straight Edge
Discontinued



1996
Plastic
Straight Edge
Discontinued



Pre-1996 Old Style
Brass
Grooved Edge
Discontinued