



AIR CONTROL SOLUTIONS

THE NELSON ACV200 PROVIDES ALL THREE TYPES OF AIR RELIEF: AIR RELIEF, VACUUM AIR RELIEF, AND CONTINUOUS AIR RELEASE UNDER PRESSURE.

9672-004 (BSP); 9672-003 (NPT)

IMPROVED DESIGN

REINFORCED SEAL PREVENTS MISALIGNMENT

IMPROVED AIR SEPARATION TO REDUCE DRIPS DURING AIR RELEASE

NEW MATERIAL RESISTANT TO PUMP LUBRICANTS

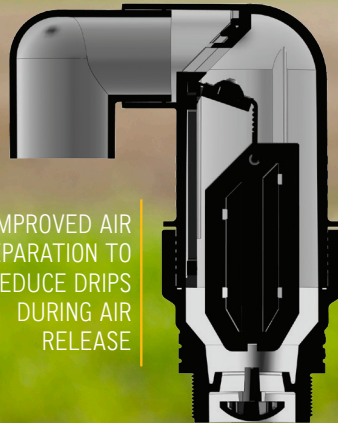

DO I NEED AIR CONTROL VALVES?

Pipes considered empty before use are really full of air. Filling an irrigation pipe system requires that the air be pushed out by the water. If air is left in the pipe the result can be poor flow efficiency, water hammer problems, poor pressure control, damaged pumps and broken pipes. And if a vacuum occurs on drip systems then emitter plugging is more likely to occur. The design and use of air control valves is a necessity for the irrigation system to operate smoothly. Typically the cost of air valves is less than a tenth of one percent of the total pipe cost. **Air valves are low cost insurance protecting expensive systems and maximizing operating efficiency.**

HOW DOES AIR GET INTO THE IRRIGATION SYSTEM?

Air comes from three primary sources. First the initial air prior to start-up. Second the water itself contains approximately 2% air volume. Thirdly the air forced into the system by pumps or drawn into the pipe under vacuum conditions.

HOW DOES AIR MOVE IN PIPES?

Air in pipes is in the form of bubbles. These air bubbles will generally migrate to the high points of a system. Velocity of water flow will move the bubbles up slope: however, if the pipeline is fairly flat or sloped downward, the velocity may not be enough to move the air pockets. The bubbles join air pockets that collect and grow in size. As the air pockets grow the effective flow area will be reduced. In severe cases the air can create an air block that stops water flow. The rapid movement of the air pockets can be the main problem causing sudden violent changes in velocity. The velocity of flow changes rapidly because of the physical fact that water is 800 times more dense than air. When large air pockets are suddenly vented the result can be a dangerous explosive burst; followed by abrupt velocity change of the water.

WHAT IS THE SOLUTION?

The solutions to air control begins long before system start-up. The following should be done.

1. Use valves such as the 800 Series that close slowly. Slowly closing a valve will minimize the potential for vacuum and reduce the amount of air taken into the line.
2. Keep the water pumping level well above the pump intake. This will avoid siphoning air along with the water into the pipeline.
3. Keep the bulk of the pipelines full if possible. Minimize refilling of the lines during the irrigation season in order to avoid repeated trapping of air.
4. Lay pipe to grade in order to have fewer high points. This will make it easier to predict where air pockets maybe trapped.

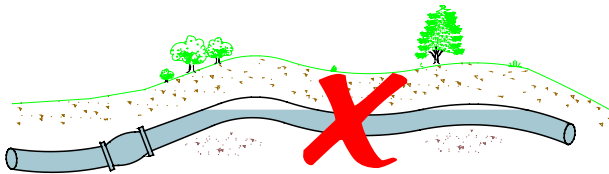
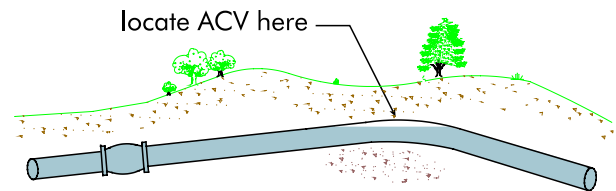

Figure 1. Avoid unnecessary high points.



Lay pipe to grade having fewer high points.

Improperly placed vacuum valves can draw unwanted air into the pipe and also oversized air valves can cause the very problem they are meant to solve. The best solution is to use the Nelson ACV200 continuous acting air valve which is designed for slow controlled release of air. If placed correctly on the pipe then the ACV200 valve will vent the major amount of trapped air during start-up. Even while under operating pressure the valve will continuously vent air. The same valve will provide vacuum relief during draining of the pipeline.

WHERE ARE AIR VALVES NEEDED?

In general a system should have air valves located as follows:

1. Place a valve at each high point in the line.
2. Place on long fairly flat or descending runs of pipe at intervals of 1500 to 2000 feet.
3. Place in-between a pump and a check valve or normally closed control valve.
4. Place downstream of dump valves with an outlet pipe longer than 10 feet.
5. Place the ACV200 in pipe sections where water velocity is in excess of 10 feet/second. If necessary, mount the ACV200 on a riser to help steady the float in high velocity conditions.
6. Adjacent to any quick closing valve and downstream of automatic control valves.

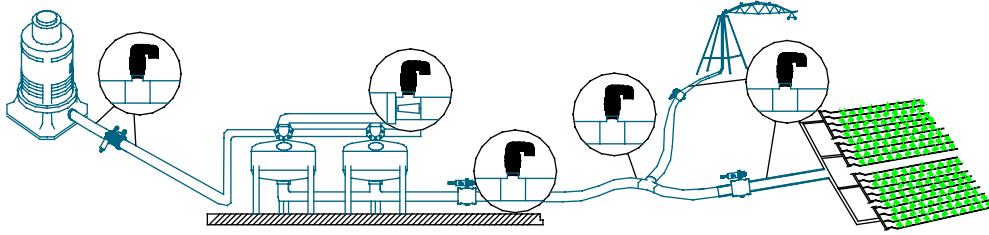

Figure 2 Typical air valve locations

WHY SELECT THE NELSON ACV200 VALVE?

There is a big difference in the air valve you choose. The Nelson ACV200 air control valve is outstanding for controlling air in irrigation systems. It provides all three types of air control in one valve:

- **AIR RELIEF.**
- **VACUUM AIR RELIEF.**
- **CONTINUOUS AIR RELEASE UNDER PRESSURE.**

The ACV200 design (patent pending) automatically does all functions and in addition features:

- *All corrosion resistant materials.*
- *Working pressure to 200 PSI.*
- *Discharge elbow with protective screen.*
- *Inlet 2" male NPT or BSP. Outlet fits 1½" PVC.*
- *Self-cleaning float guide that work in dirty water.*
- *High capacity float design resists blowing closed.*
- *Every ACV200 is water tested before shipment.*

WHAT IS INSIDE THE ACV200 VALVE?

The ACV200 is designed to fit agricultural air vent requirements. The simple design and the materials were selected to work in agricultural water. The only moving part is the float and seal. The float slides smoothly on self cleaning guides that work in dirty water. Simplicity of design can be seen in Figure 3 which is a sectional view of the assembled air valve.

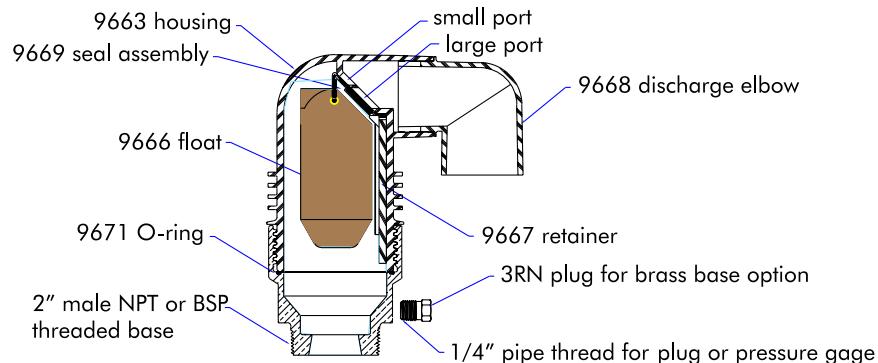

Figure 3 Sectional View of ACV200

HOW DOES THE ACV200 OPERATE?

The Nelson ACV200 operates automatically to provide air/vacuum relief and continuous air release. These different modes are shown in Figure 4a, 4b and 4c. The ACV200 has two ports, a small one and the other one large. The ports are opened and closed by the seal which responds to the movement of the specially designed float.

FIGURE 4A (OPEN). During start-up or drain-down the float is in the down position and the seal is pulled away from both the small and large ports. When both ports are open then the ACV200 can discharge enormous amounts of air. Vacuum relief is accomplished in this same mode. The performance graph in Figure 6 shows the volume of air that can pass through the full open valve. Notice the high capacity possible with the Nelson ACV200 compared to other valves.

FIGURE 4B (CLOSED). When water fills the float cavity then the seal covers both ports. The ports are sealed drip tight.

FIGURE 4 (CONTINUOUS). During operation of the system, air will collect in the float cavity causing the float to drop thus opening the small port and venting the air. The small port is sized to give a slow controlled release of air in the continuous mode. This cycle repeats automatically.

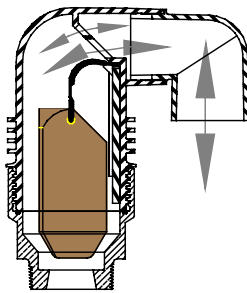

OPEN
Figure 4a

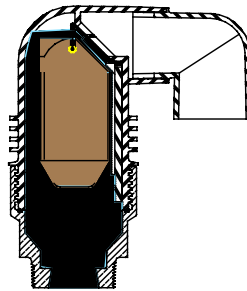

CLOSED
Figure 4b

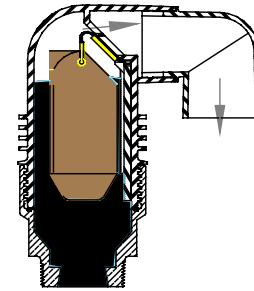

CONTINUOUS
Figure 4c

GUIDE FOR SELECTING AIR VALVES.

Generally a check of the necessary air capacity will ensure the air valves will do the job. You must calculate independently the air capacity required for each high point and each pipe section. The process is as follows:

1. The Nelson ACV200 can serve both purposes for air intake and discharge so you need to look at both the rate of air flow for draining and filling of the pipeline.

DRAINING PIPELINE CALCULATION: To find the needed air flow intake capacity use Figure 5a graph. Enter the graph using the pipe diameter and the slope of the pipe near the high point; find the maximum air intake flow requirement during draining. This amount of air flow will protect the pipe from collapse due to a vacuum.

FILLING PIPELINE CALCULATION: Next use Figure 5b graph to find the air flow requirement at the maximum rate that pipeline filling flow can occur. This amount of air flow will ensure that air can discharge as the line is filled. Keep in mind that this check is for the air flow discharge during filling of the pipeline; the irrigation design pressure can be much higher, up to 200 PSI (13.8 Bar).

2. The installed valve must handle at least the required amount of air flow determined above. Check this required flow against the flow performance graph in Figure 6. If more capacity is needed then use additional ACV200's on a tee manifold.

3. For draining and filling air flow calculations, never use more than negative 5 PSI (-0.3 Bar) for vacuum intake during the draining process. Never use more than 17 PSI (+1.2 Bar) pressure for discharge during the filling process. Don't confuse the draining and filling air pressure range with the irrigation working pressure range of the ACV200 which is from 5 PSI up to 200 PSI (13.8 Bar).

4. Repeat the same procedure for each high point on the line.

5. If the pipeline lacks clearly defined high points or there are long stretches of uniform grade then install valves at least every 2500 ft. (750 M).

Figure 5a

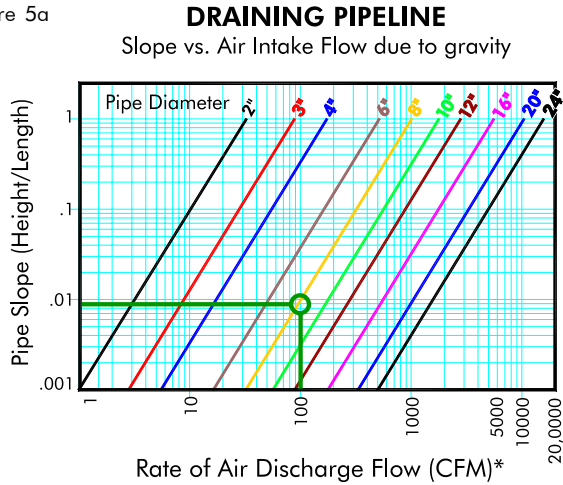
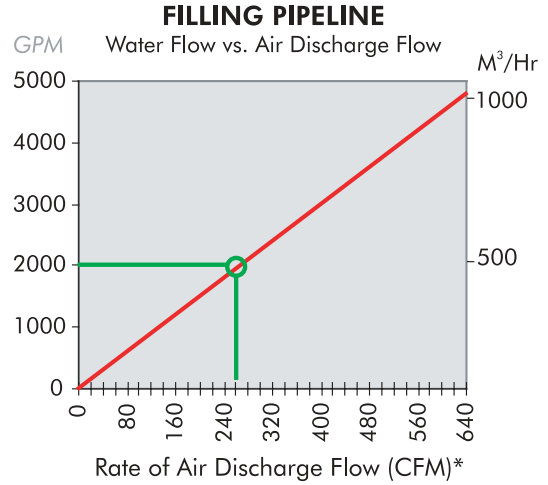
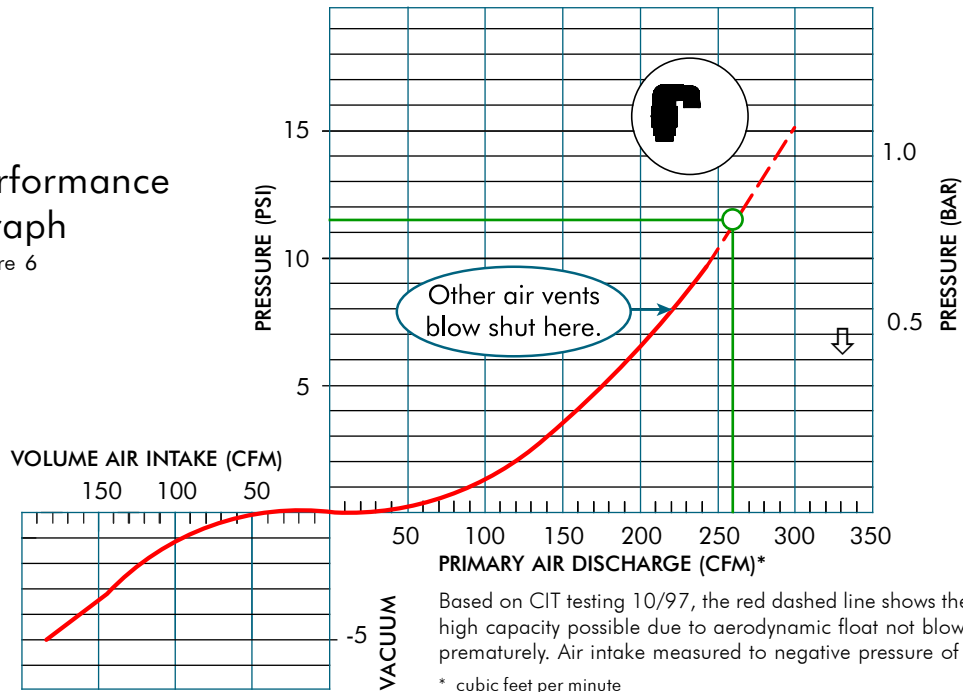

Figure 5b



Performance Graph

Figure 6



EXAMPLE CONDITIONS	RATE OF AIR FLOW REQUIRED	RESULT FROM PERFORMANCE GRAPH Figure 6
<ul style="list-style-type: none"> - Filling at 2000 GPM - Slope .01 - Pipe 8" 	<p>Look at Figure 5a to find the required air intake = 100 CFM</p> <p>Look at Figure 5b to find the required air discharge = 260 CFM</p>	<p>The ○ marked on the performance graph shows the points for this example. One ACV200 has adequate air capacity for BOTH intake and discharge. If the pipe fills at a rate of 2000 GPM then a pressure of 11.5 PSI is needed to vent all the air through one ACV200 valve during filling. However, if it is desired to discharge all the air at a lower pressure (2.7 PSI) then a second ACV200 should be used. Place one at the high point and the second one a short distance downstream.</p>

ACV200 SPECIFICATION

The air control valve will be of a continuous acting float style. The valve will automatically provide the three types of air control in one valve: Air relief; Vacuum air relief; and Continuous air release under pressure. The materials will be all corrosion resistant. The valve will have self-cleaning float guides. The valve will have a working pressure to 200 PSI. The valve float design will resist prematurely blowing closed up to a pressure of 17 PSI measured at the base. The valve will have a directional discharge elbow with protective screen. The valve will have an inlet of 2" male NPT or BSP and an outlet that fits 1 1/2" PVC. The 2" threaded base will be either plastic or brass.

Order information: Specify ACV200B for brass base or ACV200P for plastic base.
Specify 2" male NPT or 2" male BSP base threads.

MATERIALS AND DIMENSIONS

The Nelson ACV200 air control valve has the following dimensions and materials.

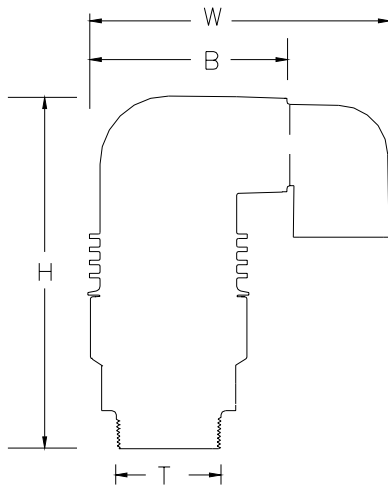

MATERIALS	
Body	Glass filled Nylon
Elbow	Glass filled Polypropylene
Base: ACV200B	Brass=CDA 844 ASTM B145-5A Federal QQ-C390, Alloy B2
Base: ACV200P	Plastic=Glass filled Polypropylene
Float	Polypropylene
Vent Seal	EPDM (#304 stainless steel reinforcement)
Seal ('O'ring)	BUNA-N

DIMENSIONS	Brass		Plastic	
	in	mm	in	mm
H	8.03	204	8.52	216
W	6.85	174	6.85	174
B	4.45	113	4.45	113
T	2 in. male NPT or BSP			

Low temperature caution: Solid ice formation inside the valve may cause breakage. Freezing temperatures may cause the vent seal to stick. If operation during freezing temperatures is required then the valve needs to be kept above freezing.

WATER HAMMER CONTROL USING NELSON 800 SERIES PRODUCTS

Water hammer is the shock caused by abruptly arresting the flow of water in a pipe. In addition to air movement, sudden velocity change could happen by rapidly filling a long pipe or in the case of pump shut down where water begins moving back toward a pump before a check valve can close. Once the shock wave starts it is very difficult to control. The water hammer shock wave move at the speed of sound in water (4660 ft./sec.). The most likely time for water hammer to occur is the period of time during start-up and shut down of a system. General rules of thumb are: (1) use a slow valve opening/closing speed; (2) control line filling to no more than 1 1/2 times operating capacity (flow); (3) limit flow velocity in the pipe to six ft./sec. Nelson valves can help prevent many water hammer problems.

CONTROL VALVE CLOSING

Nelson has developed the 800 Series valve for smooth slow closing operation. The valve features a closing speed as shown in Figure 8. The graph shows the Nelson valve compared with other brands. The critical last 50% of closing time is graphed. Notice how smoothly the flow stops.

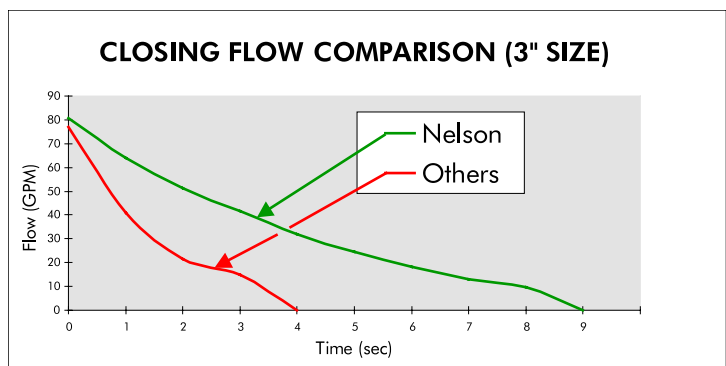

Figure 8

RATE-OF-FLOW CONTROLLED START-UP

Start-up and line filling is best controlled by using the patented Nelson Rate-Of-Flow control on the 800 Series valve. Pipeline problems and damage are many times blamed on water hammer when in fact the avoidable surge of water flow may be the condition causing the water hammer.

The Rate-Of-Flow works by means of a flow sensing plate in the flow on the upstream side of the valve. It is a significant advancement in accuracy because it works independent of line pressure responding only to the flow velocity impinging upon the sensing plate. The main application is during system filling. The control can keep the valve from fully opening. This has the effect of holding the flow back to avoid unwanted water hammer or surges which can damage system pipes. Application is also for flow rate regulation resulting in more steady hydraulic conditions upstream or downstream of the valve on an irrigation system network.

The Nelson Rate-Of-Flow control has been designed for efficiency and causes insignificant pressure loss. The control has a calibrated adjustment screw for simple setting and can work over a wide range of flow rate. Figure 9 demonstrates the effect the on water flow.

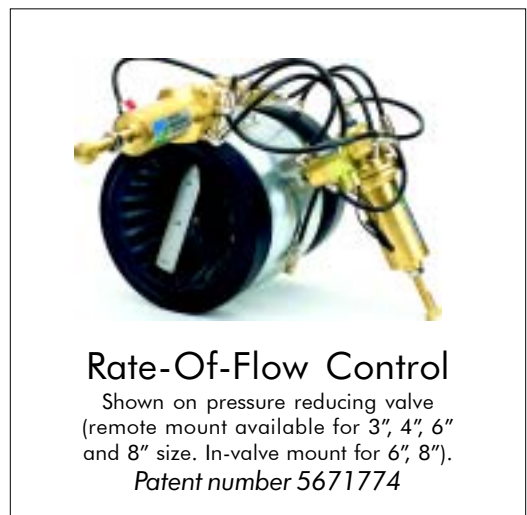
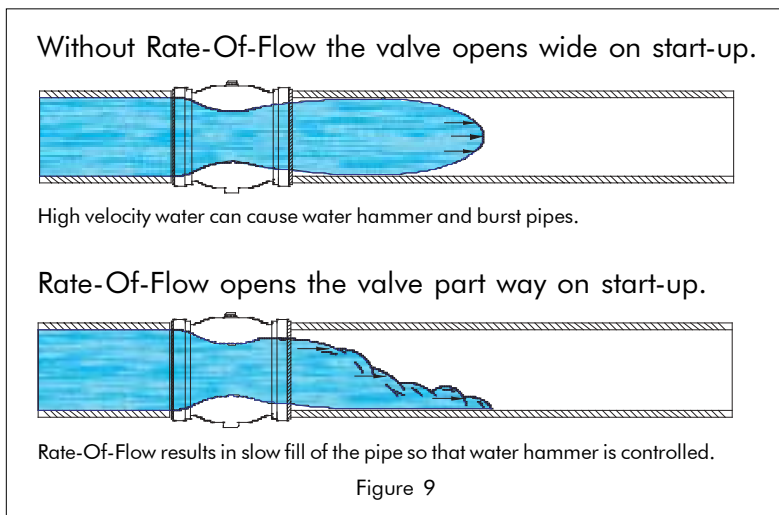

PROPORTIONAL THROTTLING

The throttling method used in the control valve is important to smooth operation. Look at the center of the Nelson valve to see the internal struts which keep the sleeve in good throttling position even at low flows. Competitive valves create much pressure loss and turbulence but the 800 Series design is engineered to avoid these problems. The 800 Series with proportional throttling is the best valve for smooth operation over the widest flow and pressure range. Figure 10 shows a sectional look at the valve.

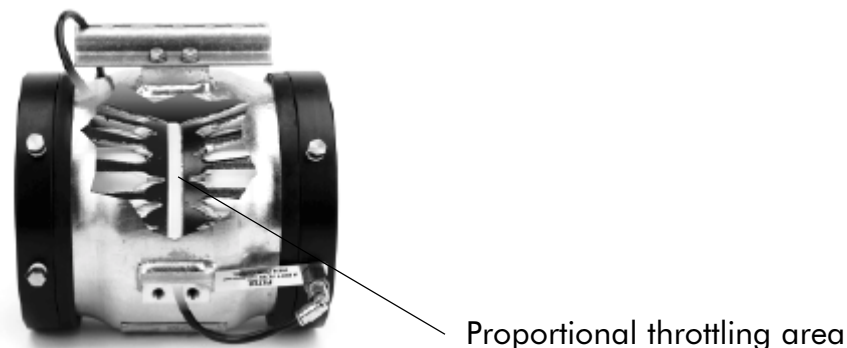
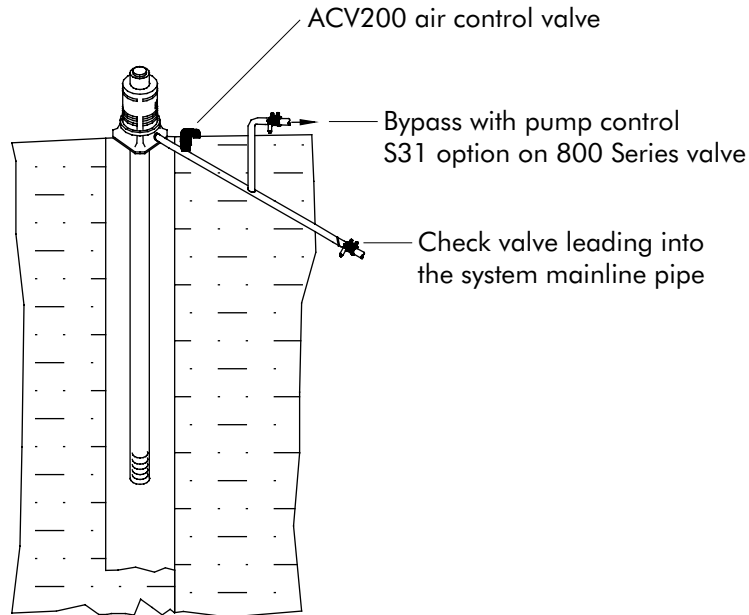

Figure 10

PUMP CONTROL VALVE (DEEP WELL - S31)

Start-up of a deep well pump can be the source of violent water hammer. The Nelson pump control valve will pass the initial surge of water through a bypass line equipped with the 800 Series valve pump control S31 option. As the pressure rises, the Nelson valve on the bypass line will slowly close, gradually diverting the flow through the check valve thereby bringing the pump on-line without causing a surge in the system. Notice the ACV200 which will help rid the pipe of air.



A WORD OF THANKS

Thank you for designing with NELSON IRRIGATION CORPORATION valve products. Our commitment at Nelson Irrigation Corporation is to provide you with the highest quality products. We work hard at manufacturing and quality assurance to satisfy your requirements. We would appreciate hearing from you. If you have any suggestions for ways to improve our products, this valve application guide, or our service please give us a call at 509-525-7660 or e-mail info@nelsonirrigation.com.

DISCLAIMER

This technical application guide is intended only as a reference for typical application considerations and may not apply to specific systems or conditions. Performance of Nelson ACV200 air control valves is dependent on many factors not exclusive to the scope of this guide. This document is subject to change through revisions and additions without notice. The information herein contained does not alter the normal *Warranty and Disclaimer*.

WARRANTY AND DISCLAIMER

Nelson Irrigation Corporation ACV200 Air Control Valves are warranted for one year from date of original sale to be free of defective materials and workmanship when used within the working specifications for which the product was designed and under normal use and service. The manufacturer assumes no responsibility for installation, removal or unauthorized repair. The manufacturer's liability under this warranty is limited solely to replacement or repair of defective parts, and the manufacturer will not be liable for any crop or other consequential damages resulting from any defects in design or breach of warranty.

THIS WARRANTY IS EXPRESSLY IN LIEU OF ALL OTHER WARRANTIES, EXPRESS OR IMPLIED, INCLUDING THE WARRANTIES OF MERCHANTABILITY AND FITNESS FOR PARTICULAR PURPOSE AND OF ALL OTHER OBLIGATIONS OR LIABILITIES OF MANUFACTURER. No agent, employee or representative of the manufacturer has authority to waive, alter or add to the provisions of warranty, nor to make representations or warranty not contained herein.