

innovation in irrigation™

NELSON**F75 BIG GUN®****F75 BIG GUN® OPERATION & MAINTENANCE INSTRUCTIONS****SET UP FOR OPERATION:**

1. Install desired Taper Ring size in ring nozzle cap. The ring nozzle cap can be sufficiently tightened by hand.
2. Install sprinkler on riser of proper size and stability.

NOTE ON LUBRICATION: The F75 sprinkler is lifetime lubricated and does not require periodic lubrication. The ball bearings in the H.D. lower bearing operate in a water resistant lubricant that is packed in the housing cavities and retained by seals. If repair of the lower bearing is done, it is recommended to use Nelson #6143 lubricant or a good grade of water resistant lubricant such as Lubriplate 130-AA.

BE CAREFUL: Read operating instructions before operating sprinkler or making any adjustments. Never make adjustments or perform service while sprinkler is in operation. Stand clear of operating sprinkler. Stand clear of high velocity water stream. Never direct water stream onto roadway or electrical transmission lines.

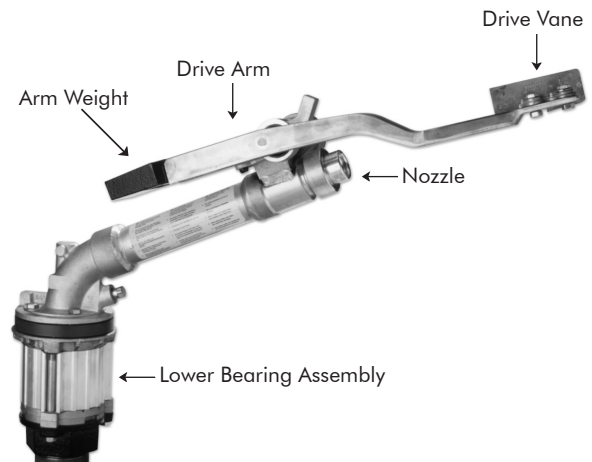

The **F75** is available in fixed trajectory angles of **21° & 24°**

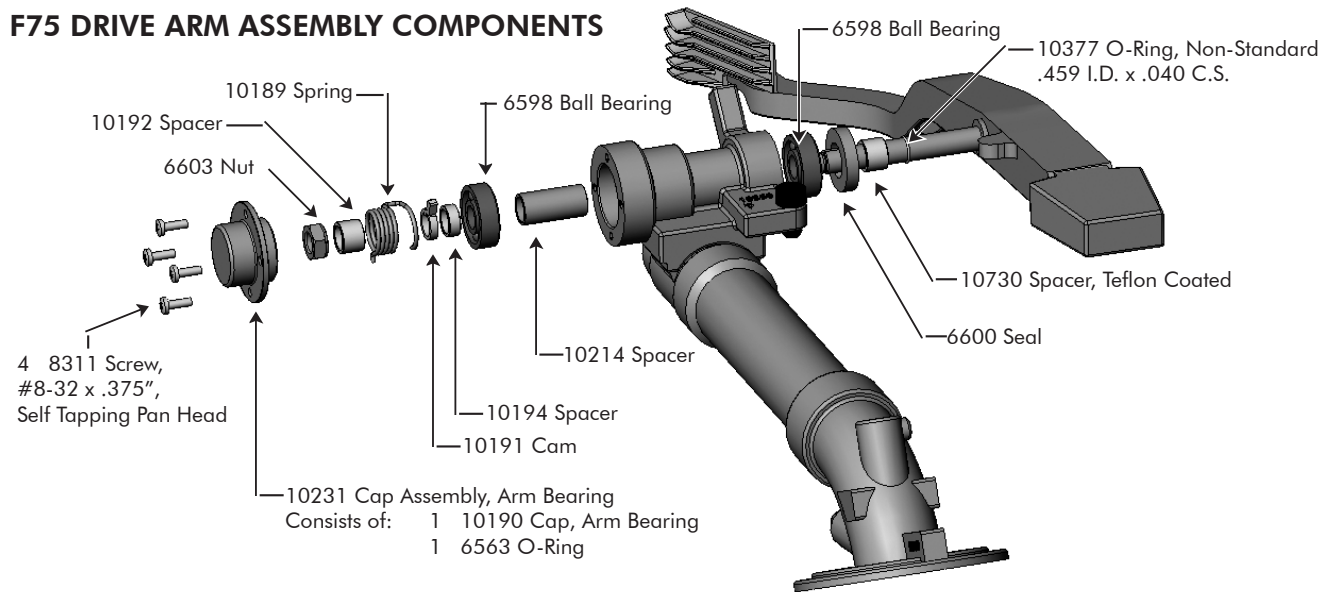
F75 DRIVE ARM ASSEMBLY COMPONENTS

WARRANTY AND DISCLAIMER: Nelson Big Gun® Sprinklers are warranted for one year from date of original sale to be free of defective materials and workmanship when used within the working specifications for which the product was designed and under normal use and service. The manufacturer assumes no responsibility for installation, is limited solely to replacement or repair of defective parts, and the manufacturer will not be liable for any crop or other consequential damages resulting from any defects or breach of warranty. THIS WARRANTY IS EXPRESSLY IN LIEU OF ALL OTHER WARRANTIES, EXPRESS OR IMPLIED, INCLUDING THE WARRANTIES OF MERCHANTABILITY AND FITNESS FOR PARTICULAR PURPOSES AND OF ALL OTHER OBLIGATIONS OR LIABILITIES OF MANUFACTURER. No agent, employee or representative of the manufacturer has authority to waive, alter or add to the provision of the warranty, nor to make any representations or warranty not contained herein.

SEE FRONT FOR DRIVE ARM ASSEMBLY COMPONENTS / SEE PARTS LIST FOR COMPLETE PARTS LIST AND DESCRIPTIONS

DISASSEMBLY/REASSEMBLY

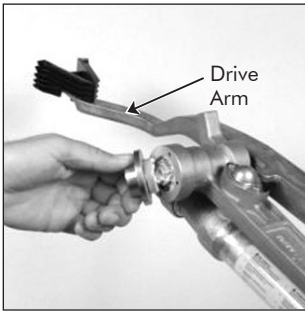

STEP 1 (Drive Arm)
 Remove four #8311 screws holding #10231 cap. Using an 11/16" socket, remove the #6603 nut from left side of arm.

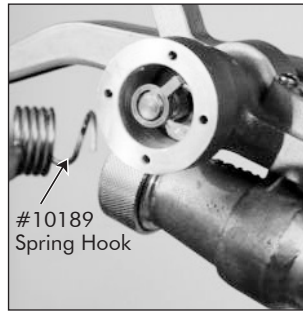

STEP 6
 Continue the sequence of sliding onto the drive arm shaft the #10192 spacer and the #10189 spring. *Notice the hook end of the spring goes in first so the spring wire loops around the finger of the #10191 cam.*



STEP 2
 Holding the barrell, pull arm from the right side until it is free from hub.



STEP 7
 Thread on #6603 nut. Torque to 25 ft. lbs. using the 11/16" socket (metric torque = 34 NM or 3.5 MKG).

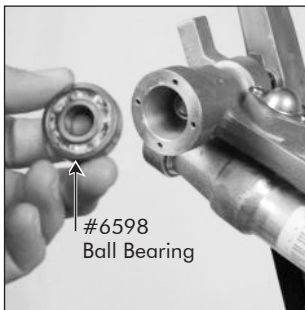

STEP 3 (Drive Arm)
 Inspect both left and right #6598 ball bearings. Replace if worn or corroded. Inspect #6600 seal as well. Lubricate seal with silicon grease prior to reassembly.

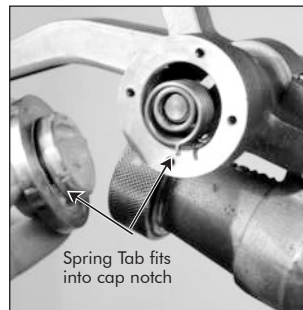

STEP 8
 Replace the lubricant. Replace cap making sure that the notch engages the spring tab. Replace screws. Assure the drive arm moves freely.

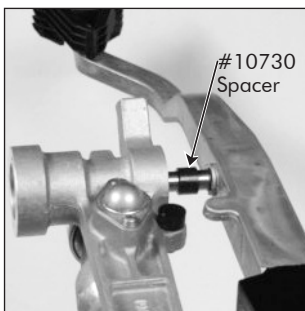

STEP 4
 Assure the #10377 O-ring and #10730 Spacer is on the drive arm shaft. Push the shaft all the way into the right arm hub. From the left side slide onto the arm shaft, in sequence, the #10214 spacer, #6598 bearing, #10194 spacer, #10191 cam.

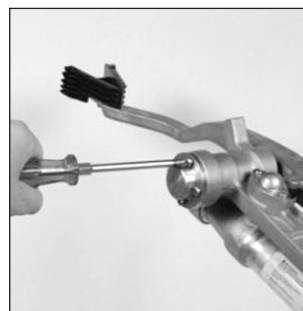

STEP 5
 Make sure the #10191 cam is correctly keyed into the slot on the drive arm shaft. Notice the correct orientation of the finger on the cam for proper arm operation.

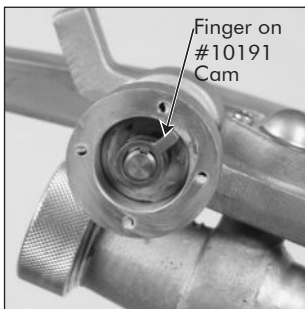

SEE BACK PAGE FOR PARTS LIST

DISASSEMBLY (LOWER UNIT)

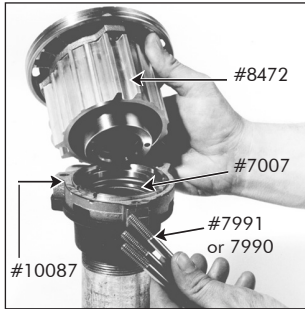

STEP 1

Remove three #7990 or #7991 bolts from flange. Separate #8472 housing from #10087 Spacer Assembly. Remove #7007 O-Ring from #10087 Spacer Assembly.

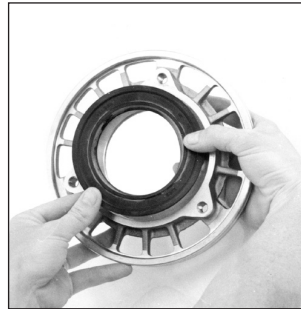

STEP 6

Place #6997 Lip Seal into #7763 cover as shown with Nelson name toward ball bearing. Pack #6559 Bearing with #6143 lubricant or equivalent. (See "Notes on Lubrication" on the front cover.) Press bearing into #6858 Cover. Slide cover assembly onto bearing shaft. CAUTION: Do not get grease on brake surfaces. To clean plastic brake, use soap and water (solvents may damage plastic). Clean #6858 cover with acetone.

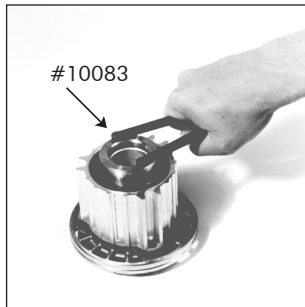

STEP 2

The #10083 Retainer Assembly is removed by using spanner wrench. To hold the #7031 Shaft Assembly from rotating insert two 5/16-18 bolts (#6635) into shaft top. Clamp bolt heads into a vise securely. Remove retainer and #8472 Housing from bearing shaft.

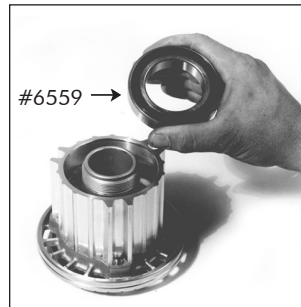

STEP 7

Assemble #6566 Gasket. Press on #8472 Housing. Fully pack housing with #6143 Lubricant. Assemble #6559 Bearing into housing.



STEP 3

Remove the #6998 Seal. To remove the two #6559 Bearings use a hammer and three blocks of wood. Lightly tap uniformly around inner race of bearing until removed. Bearings are removed from opposite sides of the #8472 Housing.

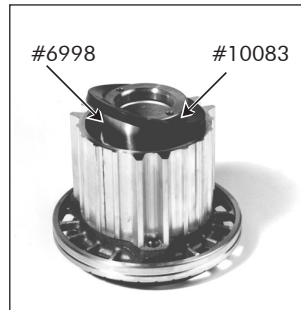

STEP 8

Install #6999 O-Ring in #7003 Retainer and assemble retainer on shaft. Using method described in disassembly (Lower Unit) instructions Step 12, secure bearing shaft from rotating. Torque Retainer to 95-110 ft. lbs. Apply a light coating of #9673 Silicone Grease to O.D. of Retainer. Assemble #6998 Lip Seal. Orient with lip side out. Metric Torque = 129-149 NM or 13-15 MKG.

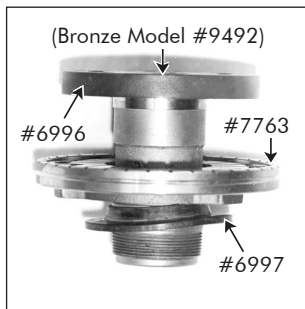

STEP 4

Remove #7763 Cover from shaft. Remove #6997 Seal from cover. Remove #6996 Brake Ring and #7009 Dust Seal from shaft.

Inspect all parts for wear and replace as required.

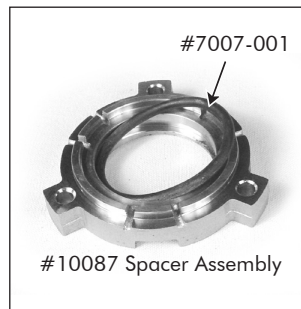

STEP 9

Install 7007-001 O-Ring into Spacer and mount onto assembly.



REASSEMBLY (LOWER UNIT)

STEP 5

Assemble #7009 Dust Seal onto #7031 Shaft Assembly. Slide #6996 Brake Ring onto shaft. Locate the four studs of the brake ring in the center holes between the smaller threaded holes.



STEP 10

Assemble #8967 O-Ring into the Flange Adapter. Mount Flange Adapter using required Bolts. Torque Bolts to 130-150 inch pounds.

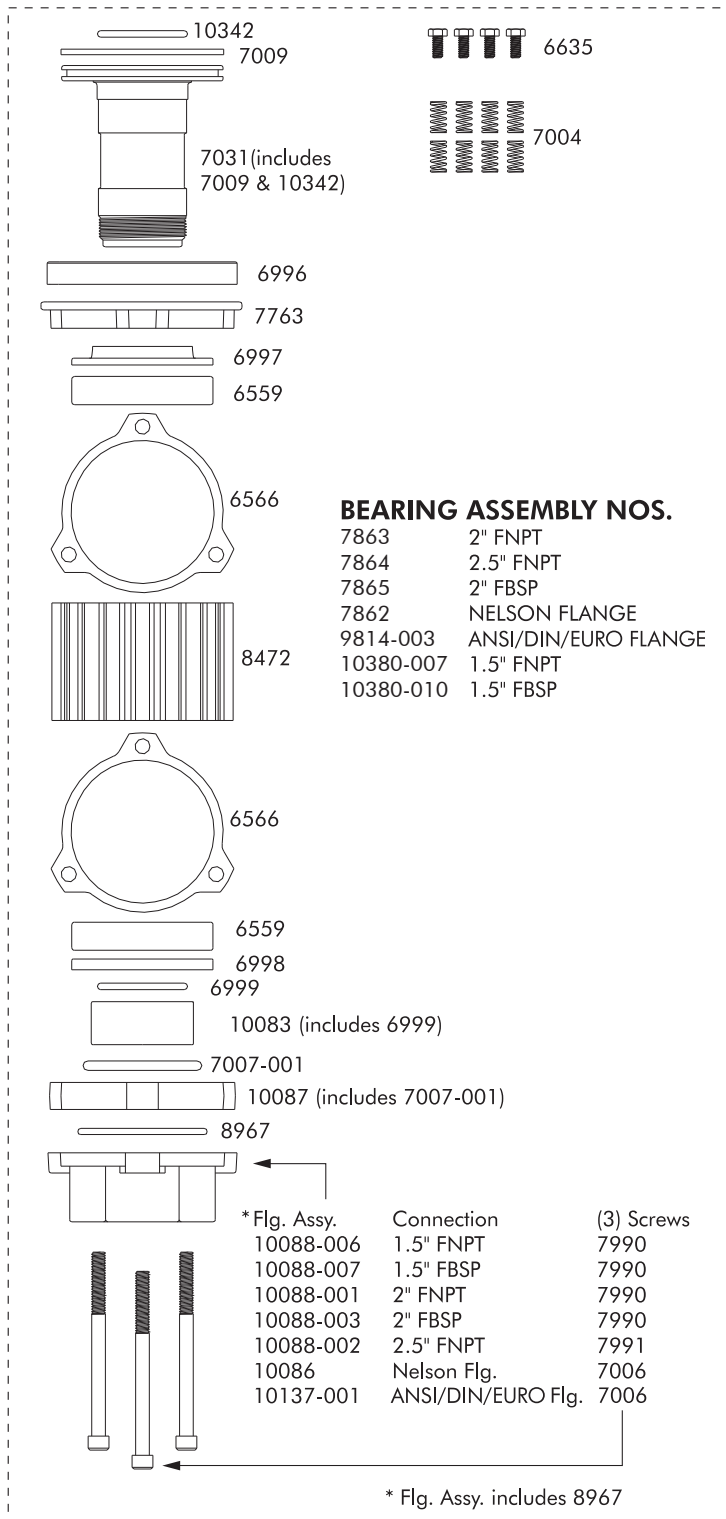

BEARING ASSEMBLY NOS.

| | |
|-----------|----------------------|
| 7863 | 2" FNPT |
| 7864 | 2.5" FNPT |
| 7865 | 2" FBSP |
| 7862 | NELSON FLANGE |
| 9814-003 | ANSI/DIN/EURO FLANGE |
| 10380-007 | 1.5" FNPT |
| 10380-010 | 1.5" FBSP |

BEARING ASSEMBLY HD 100

| part number | description | qty. |
|-------------|--|------|
| 6559 | Bearing, Ball, 50 x 80 x 16mm | 2 |
| 6566 | Gasket, Housing - HD100 | 2 |
| 6635 | Screw, .3125 - 18 x .688" Hex Hd Cap | 4 |
| 6996 | Ring, Brake - HD100 | 1 |
| 6997 | Seal, Upper - HD100 | 1 |
| 6998 | Seal, Center - HD100 | 1 |
| 6999 | O-Ring, -224 | 1 |
| 7004 | Spring, Brake - HD100 | 8 |
| 7006 | Screw, .312-18 x 3.50" Hex Skt Hd Cap | 3 |
| 7007-001 | O-Ring, -331 Special, w/ grease & graphite | 1 |
| 7009 | Seal, Dust - HD100 | 1 |
| 7031 | Shaft Assembly - HD100 | 1 |
| 7763 | Cover, Full Circle - HD100 | 1 |
| 7990 | Screw, .312-18 x 4.25" Hex Hd Cap | 3 |
| 7991 | Screw, .312-18 x 4" Hex Skt Hd Cap | 3 |
| 8472 | Housing - HD100 | 1 |
| 8967 | O-Ring -231, Special | 1 |
| 10083 | Retainer Assembly - HD100 | 1 |
| 10086 | Flange Assembly, Nelson | 1 |
| 10087 | Spacer Assembly - HD100 | 1 |
| 10088-001 | Flange Assembly, 2" FNPT | 1 |
| 10088-002 | Flange Assembly, 2.5" FNPT | 1 |
| 10088-003 | Flange Assembly, 2" FBSP | 1 |
| 10088-006 | Flange Assembly, 1.5" FNPT | 1 |
| 10088-007 | Flange Assembly, 1.5" FBSP | 1 |
| 10137-001 | Flange Assembly, ANSI/DIN/Euro | 1 |
| 10342 | O-Ring, -225 | 1 |

MOUNTING HARDWARE

| part number | description | qty. |
|-------------|--------------------------------------|------|
| 7000 | Gasket, Flange | 1 |
| 7039 | Screw, .312-18 x .75" Hex Skt Hd Cap | 6 |
| 10149 | Gasket, Euro Flange | 1 |

FLANGE GASKET AND FASTENERS FOR MOUNTING GUN

