

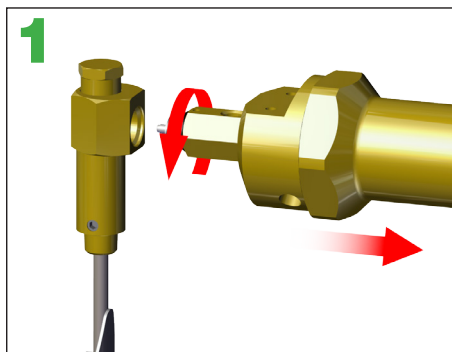

800 Series Rate-of-Flow

#12305-001 Upgrade Kit Installation



1
Back-off adjustment screw to remove pressure from the spring. Unthread pilot from stem.

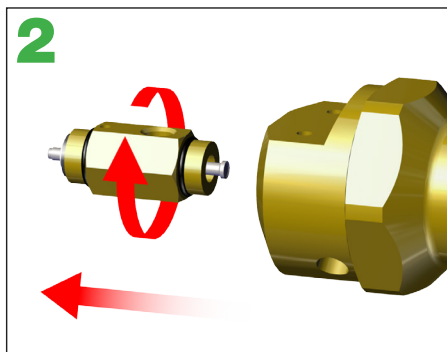

2
Unthread connector from the spool housing.

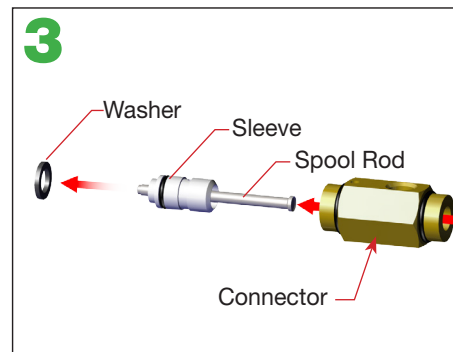

3
Remove the washer (6495) on the connector. Push the spool rod through the connector to remove both the spool rod and sleeve. Discard the washer, sleeve and spool rod.

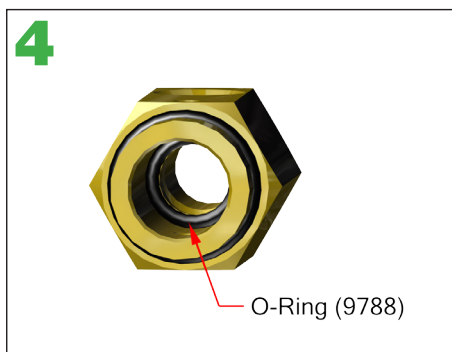

4
Replace the o-ring (9788) inside of the connector.

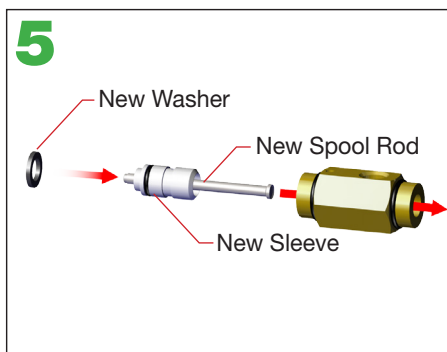

5
Replace the washer, sleeve (10724), and spool rod (9790) with the parts included in the upgrade kit.

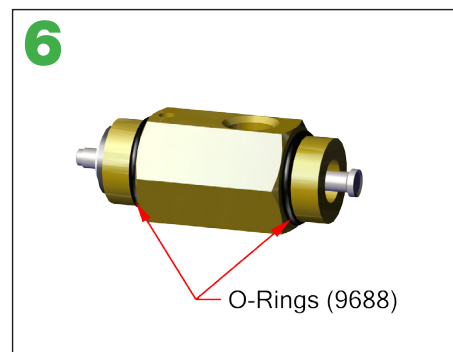

6
Replace the o-rings (9688) on the threads of the connector.

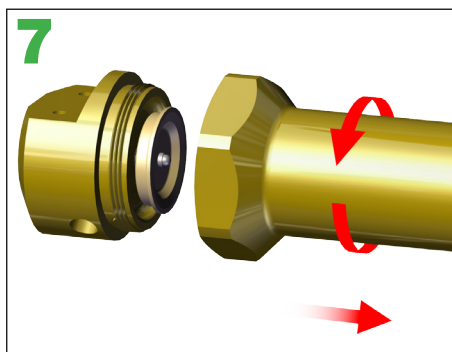

7
Unthread spool housing from the spring housing.

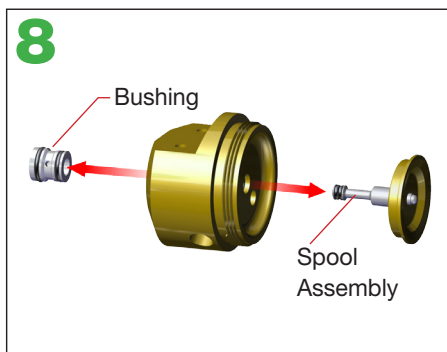

8
Remove and discard the old spool assembly and old bushing from the spool housing.

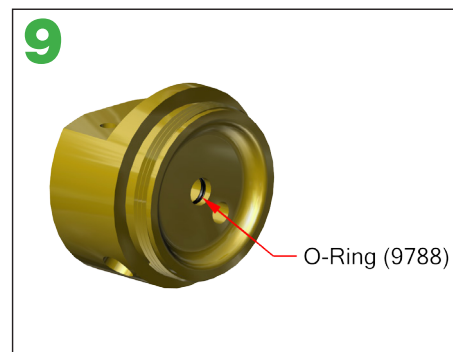

9
Replace the o-ring (9788) inside of the spool housing. Make sure inside of spool housing is free of debris. NOTE: Use an o-ring pick to remove and replace the o-ring.

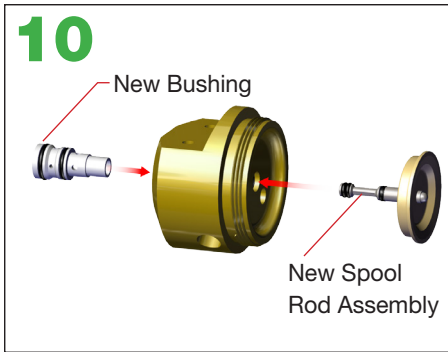

Insert the new bushing (11908) and new spool rod assembly into the spool housing.

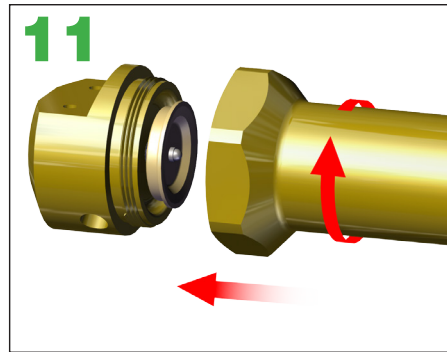

Thread the spool housing back into the spring housing.

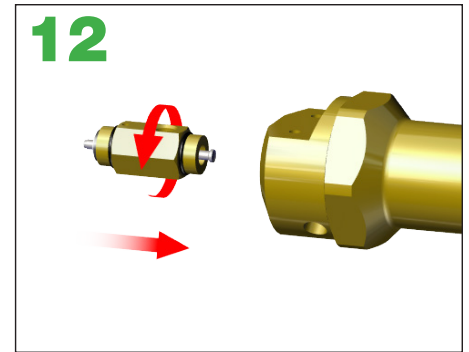

Thread the connector into the reassembled pilot body.

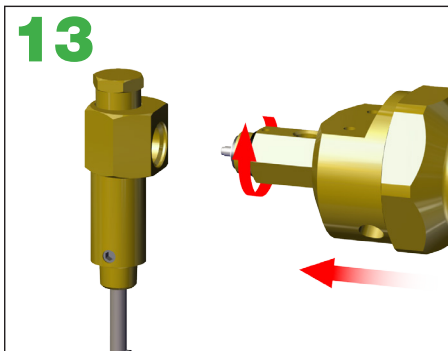

Thread the connector and pilot back onto the stem, making sure the washer is still in place.